

RGC[®]
REIMANN & GEORGER CORP.
HOISTING - MARINE - CONSTRUCTION

VL16092

VERTICAL LIFT

INSTRUCTIONS

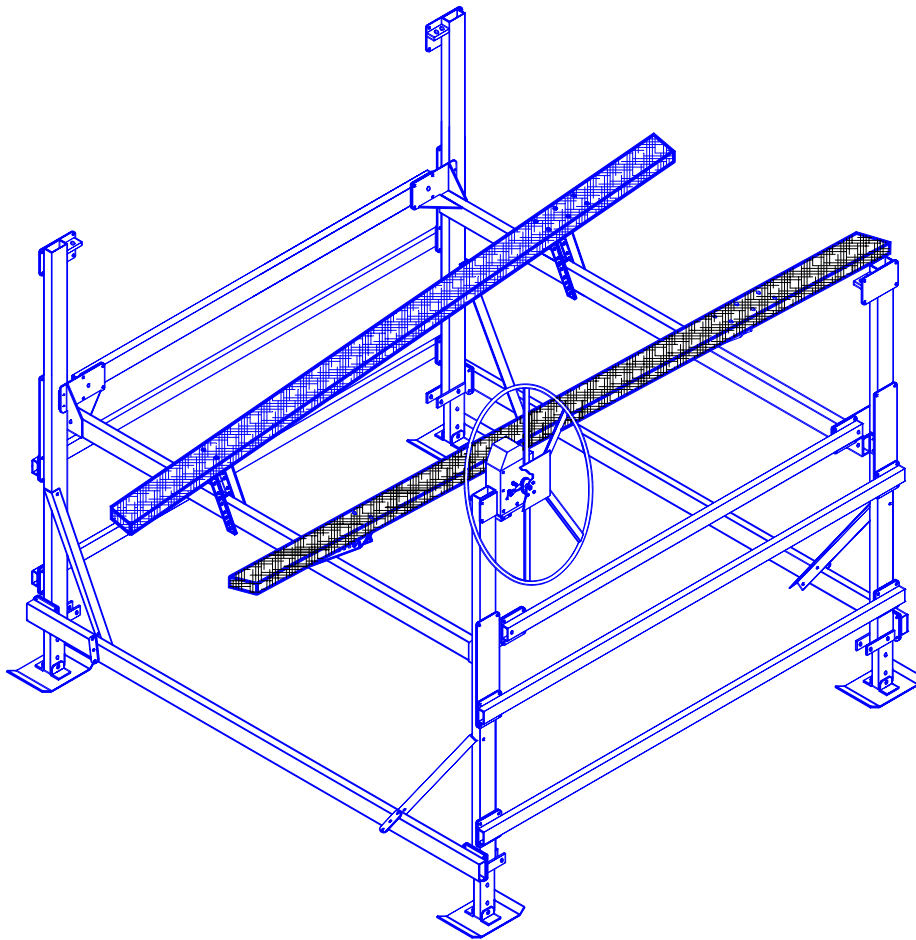

REIMANN & GEORGER CORPORATION
MARINE PRODUCTS
P/N 6112069

BUFFALO, NY
11/16/99

PRE-LIFTING CHECKLIST

The lift and related equipment must be thoroughly inspected prior to each use. Only those who have read and understood this entire manual and related equipment manuals are qualified to do this inspection. This checklist is to be used as a guideline in conjunction with the maintenance and inspection procedures outlined in this manual. It is recommended that this checklist be maintained as a permanent record.

- Insure the lift installation will clear all power lines and obstructions.
- Insure all structural members of the lift are free of defects and damage that may affect the integrity.
- Insure that an electric drive, if used, has been inspected and installed by a certified electrician in accordance with local electrical codes. A Ground Fault Circuit Interrupter (G.F.C.I.) must be installed by your electrician and work properly.
- Insure that any user or dealer installed locking devices have been removed before operating the lift.
- Operate the lift first without, and then with, your boat on the platform to test the operation of both the lift and the winch.
- Insure the boat is properly positioned on the lift before doing any raising or lowering.
- Insure the lift is not being used beyond its rated capacity.
- Insure any drain plug is in place on the boat before launching.
- Conduct the wire rope inspection procedure described in Chapter 5 at least monthly.
- Insure the leg pins connect the vertical legs to the adjustable legs. Insure the leg height has been properly adjusted according to the water depth.
- Insure the frame and platform fastenings are tight.
- Insure the lower diagonal braces are installed in each corner.
- Insure the frame is level and square according to the dimensions shown in Figure 3-6, Chapter 3.
- Insure the cable end loops of the load and spreader tubes are fastened to the bracket at the bottom of each vertical leg.
- Insure the cable studs opposite the cable end loops in the platform assembly are tight. If tightening is needed, follow the sequence described in Section 3.8 of Chapter 3. Then tighten the jam nuts to the cable nuts to lock the position.
- Insure the winch is securely fastened to vertical leg "A".
- Insure the handwheel has been attached to the winch hubplate.
- Insure the spinner knob is attached to the handwheel using the preassembled hardware.
- Insure the A-B load tube cable is properly reeved and fastened for correct winch operation.
- Insure set screw or cable clamp securing wire rope end to the drum is tight and in good condition.
- When facing the front of the handwheel, insure that the wire rope winds and unwinds from the right side of the winch. This reeving will raise the platform when the handwheel is turned clockwise, and lower the platform when the handwheel is turned counterclockwise. The brake pawl must click, meaning the brake is operative.
- Insure all guards are in place before operating the winch.

PRE-LIFTING CHECKLIST (CONTINUED)

Insure the plastic caps are installed onto the tops of the vertical legs and the ends of the upper short horizontal tubes.

INSPECTOR: _____ **DATE:** _____

TABLE OF CONTENTS

CHAPTER	TITLE	PAGE
1	SAFETY	1
1.1	Introduction	1
1.2	Safety Definitions	1
1.3	Equipment Safety Labels	1
1.4	Equipment And Personnel Safety	1
1.5	Installation Safety	2
1.6	Operating Safety	2
1.6.1	General	2
1.6.2	Safety When Raising the Boat	3
1.6.3	Safety When Lowering the Boat	3
1.7	Maintenance and Storage Safety	3
2	SPECIFICATIONS	5
2.1	Technical Data	5
2.2	Nameplate and Serial Number Tag	5
2.3	Optional Equipment	5
3	INSTALLATION AND SETUP	7
3.1	Pre-Installation Checks	7
3.2	Prior To Setup	7
3.3	Vertical Leg Assembly	8
3.4	Frame Side Assembly	9
3.5	Platform Assembly	9
3.6	Mounting The Platform To The Frame	10
3.7	Mounting The Lower Diagonal Braces	11
3.8	Platform Reeving And Adjustment	12
3.9	Winch/Handwheel Mounting	13
3.10	Reeving The Winch	14
3.11	Moving Lift To Operating Position	15
4	OPERATION	16
4.1	Before Operating The Lift	16
4.2	Testing Winch Operation	16
4.3	Raising And Lowering The Platform	17
4.4	Securing Lift When Not In Use	17
5	INSPECTION AND MAINTENANCE	18
5.1	General Maintenance Rules	18
5.2	Wire Rope Inspection Procedure	18
5.3	Annual Inspection	19
5.4	Annual Winch Maintenance	19
5.5	Storage Procedure	20
6	TROUBLESHOOTING	21
7	PARTS LISTS	23
7.1	#3616000 VL 16092 Boat Lift Bundles	23
7.1.1	#3616020 VL 16092 Bundle 1 of 2	23
7.1.2	#3616021 VL 16092 Bundle 2 of 2	23
7.2	VL Extension Legs	23
7.3	#3679355 VL Bunk Carton of Parts	23
7.4	#3603778 VL Bunk Bundle	24

TABLE OF CONTENTS

CHAPTER	TITLE	PAGE
7.5	#3616033 VL 16092 Carton of Parts.....	24
7.6	#3655255 VL Hardware.....	24
7.7	#3703811 VL Handwheel 4'	24
	LIMITED WARRANTY	25

LIST OF FIGURES

FIGURE	DESCRIPTION	PAGE
2-1	Typical Product Nameplate	5
3-1	Vertical Lift Frame & Platform Assembly	7
3-2	Lift / Dock Placement Options	8
3-3	Vertical Leg Assembly	8
3-4	Frame Side Assembly	9
3-5	Platform Assembly–Top View	10
3-6	Frame Squaring Assembly / Table	11
3-7	Lower Diagonal Brace Assembly.....	12
3-8	Cable Reeving & Adjustment.....	13
3-9	VL Handwheel / Winch Mounting & Reeving.....	14
5-1	Wire Rope Components	19

1 SAFETY

1.1 INTRODUCTION

Your Reimann & Georger Corporation Marine Products Aluminum Vertical Lift has been engineered to provide lifting performance, long term economics and safety advantages that no other type can match. However, even a well-designed and well-built lift can malfunction or become hazardous in the hands of an inexperienced and/or untrained user.

Therefore, read this manual and related equipment manuals thoroughly before operating your lift to provide maximum safety for all operating personnel, and to get the maximum benefit from your equipment.



WARNING:

DO NOT OPERATE THIS LIFT WITHOUT STUDYING THIS ENTIRE MANUAL. FAILURE TO DO THIS CAN LEAD TO EQUIPMENT MISUSE WITH RESULTING DAMAGE AND/OR SERIOUS PERSONAL INJURY. CONTACT YOUR RGC® MARINE DEALER IF YOU HAVE ANY QUESTIONS.

1.2 SAFETY DEFINITIONS

A safety message alerts you to potential hazards that could hurt you or others or cause property damage. The safety messages or signal words for product safety signs are **DANGER**, **WARNING**, and **CAUTION**. Each safety message is preceded by a safety alert symbol and is defined as follows:

DANGER: Indicates an imminently hazardous situation which, if not avoided, **will** cause death or serious injury. This safety message is limited to the most extreme situations.

WARNING: Indicates a potentially hazardous situation which, if not avoided, **could** result in death or serious injury.

CAUTION: Indicates a potentially hazardous situation which, if not avoided, **may** result in minor or moderate injury. It may also be used to alert against unsafe practices and property-damage-only accidents.

1.3 EQUIPMENT SAFETY LABELS

These labels warn you of potential hazards that could cause injury. Read them carefully. If a label comes off or becomes illegible, contact a Reimann & Georger Corporation dealer for a free replacement.

1.4 EQUIPMENT AND PERSONNEL SAFETY

1. Do not use the lift if it shows any signs of damage.
2. Do not exceed the rated maximum lifting capacity of this equipment.
3. When using a direct drive or motorized friction drive, understand the use of all controls and connections provided with it.



WARNING:

ALL ELECTRIC DRIVES MUST BE INSTALLED AND INSPECTED BY A CERTIFIED ELECTRICIAN IN ACCORDANCE WITH LOCAL ELECTRICAL CODES. THIS INSTALLATION MUST INCLUDE A PROPERLY WORKING GROUND FAULT CIRCUIT INTERRUPTER. (G.F.C.I.)

4. Never try lifting anything other than a boat with this equipment.
5. Never allow people in the boat any time it is suspended above the water on the platform.



WARNING:

DO NOT STAND OR WALK ON THE PLATFORM WHILE IT IS IN ANY RAISED POSITION. THIS CAN CAUSE SERIOUS PERSONAL INJURY.

6. Do not allow anyone to swim or play under, near or on the lift at any time.

1.5 INSTALLATION SAFETY

1. Insure that all bolts and nuts are fastened securely prior to operation.
2. Insure the pulleys spin freely. If any pulley binds, replace it immediately.
3. Do not weld or otherwise modify the lift. Such alterations may weaken the structural integrity of the lift and void the warranty.
4. All lifting accessories such as pontoon brackets, pivoting bunks, and guide-ons, must be commercially manufactured, have a rated load capacity equal to that of the lift, and be properly maintained and installed.
5. Insure that the frame is level and square.
6. The following precautions must be observed when lifting any part of this equipment:
 - a. Be sure of your footing.
 - b. Bend your knees and lift with your legs.
 - c. Hold the equipment section close to your body when lifting.
7. Wear heavy leather gloves when handling wire rope. Insufficient hand protection when handling wire rope can cause personal injury.

1.6 OPERATING SAFETY

1.6.1 General

1. Never use this equipment beyond its rated capacity. This can damage the lift and/or boat with resulting serious personal injury.
2. Before allowing anyone to operate the lift, be certain they fully understand the proper operating procedure.
3. Completely remove any user or dealer installed locking devices before operating the lift.
4. Follow the Pre-Lifting Checklist before operating.
5. Do not try lifting or launching your boat in rough water conditions. This can damage your boat and/or the lift.
6. The boat must be secured on the lift before raising or lowering. Failure to do this can cause equipment damage and/or serious personal injury.
7. Keep people and pets clear during operation of the lift.
8. Keep fingers and clothing clear of all moving parts.
9. Check the lift periodically for frayed cables and/or binding pulleys.
10. Do not attempt to make any adjustments on the lift while it is being operated.

11. Contact your dealer if the winch mechanism fails to perform as described in the Operation chapter of this manual.
12. Never tamper with the winch mechanism. This can cause equipment damage.
13. Do not operate the lift under the influence of drugs, alcohol, or medication.
14. Never use the lift to hang or store any auxiliary equipment such as boating hardware.

1.6.2 Safety When Raising the Boat

1. The handwheel or power drive must turn clockwise when raising the platform. The brake pawl must click, indicating that the brake is operative.
2. Do not try to raise the boat beyond the maximum lifting height of the platform.



WARNING:

IF YOU HAVE TO TURN THE HANDWHEEL COUNTERCLOCKWISE TO RAISE THE PLATFORM, YOU HAVE REEVED THE WINCH INCORRECTLY. YOU WILL IMMEDIATELY ENCOUNTER STRONG RESISTANCE WHICH CAN LEAD TO WINCH DAMAGE AND/OR CABLE BREAKAGE.

1.6.3 Safety When Lowering the Boat

1. The handwheel or power drive must turn counter-clockwise when lowering the platform.



WARNING:

IF YOU HAVE TO LOWER THE PLATFORM BY TURNING THE HANDWHEEL CLOCKWISE, YOU HAVE REEVED THE WINCH INCORRECTLY. THE BRAKE PAWL WILL NOT BE EFFECTIVE WHICH CAN CAUSE AN UNCONTROLLED SPIN-DOWN OR “FREEWHEEL” OF THE HANDWHEEL. IF FREEWHEELING OCCURS, NEVER TRY TO STOP IT.

2. Counter-clockwise rotation of the handwheel allows the self-activating brake mechanism to provide a controlled lowering of the platform.



WARNING:

NEVER RELEASE THE BRAKE PAWL OF THE WINCH. THIS CAN TRIGGER AN UNCONTROLLED SPIN-DOWN OR “FREEWHEEL” OF THE HANDWHEEL.

3. Do not continue lowering the platform after the boat floats freely. Excessive slack in winch cable may cause binding.

1.7 MAINTENANCE AND STORAGE SAFETY

1. At least once a year, the lift must be thoroughly inspected as described in the Maintenance chapter of this manual.
2. Completely lower the platform before performing any type of maintenance or repair.



WARNING:

NEVER ALLOW ANYBODY TO WORK IN OR ON THE BOAT WHEN IT IS SUSPENDED ABOVE THE WATER ON THE LIFT.

3. Immediately replace any components found to be defective as described in Chapter 5—Inspection and Maintenance.

2.3 OPTIONAL EQUIPMENT

The following options are available which enable you to customize your lift for your particular operation. Installation instructions are provided as part of each option kit.

1. **Acrylic Canopy**—Boats tucked neatly under the heavy duty canopy are protected from the elements, reducing the need for boat coverings. Various canopy sizes and colors are available.
2. **Friction Drive**—Motorized drive turns standard handwheel to raise and lower boat.
3. **Full Length Guide-On**—Cushioned guide-ons make entering the lift easy in various water conditions.
4. **Motor Stop**—Assists in positioning boat on the lift for balanced lifting.
5. **VL Transport Kit**—Makes installation and removal of boat lift easier. You can purchase the complete kit or desired components.
6. **Pontoon Deck Brackets**—These brackets are designed to lift pontoon boats from under the deck. The vertical leg bumper kit is included which supplies carpeted side bumpers. Wood for bunks is not supplied.
7. **Pontoon Cradles**—Cradle brackets designed for lifting pontoon boats from under the pontoons. The vertical leg bumper kit is included which supplies carpeted side bumpers. Wood for bunks is not supplied.
8. **Deep Water Extension Legs**—Adjustable legs available in pairs with bracing. Standard lengths are 4', 6', 8', and 10'.
9. **VL Upper / Lower Bumper Kit**—This cushioned wood kit mounts onto your lift in key locations to protect your boat while entering and exiting the lift in various water conditions. This is both a “stand alone” kit and a kit automatically supplied with the pontoon deck brackets and pontoon cradles.

3 INSTALLATION AND SETUP

3.1 PRE-INSTALLATION CHECKS

1. Do not assemble the lift if any part shows any sign of damage.
2. Do not weld or otherwise modify the lift. Such alterations may weaken the structural integrity of the lift and void the warranty.
3. All lifting accessories such as pontoon brackets, pivoting bunks, guide-ons, and slings shall be commercially manufactured, have a rated load capacity equal to that of the lift, and be properly maintained and installed. Consult the manufacturer's separate instructions provided for these accessories.



WARNING:

ALL ELECTRIC DRIVES MUST BE INSTALLED AND INSPECTED BY A CERTIFIED ELECTRICIAN IN ACCORDANCE WITH LOCAL ELECTRICAL CODES. THIS INSTALLATION MUST INCLUDE A PROPERLY WORKING GROUND FAULT CIRCUIT INTERRUPTER. (G.F.C.I.)

3.2 PRIOR TO SETUP

The part reference numbers and letters used in the subassembly drawings of sections 3.3 through 3.9 are the same as those shown in Figure 3-1 and listed in the parts lists of Chapter 7.

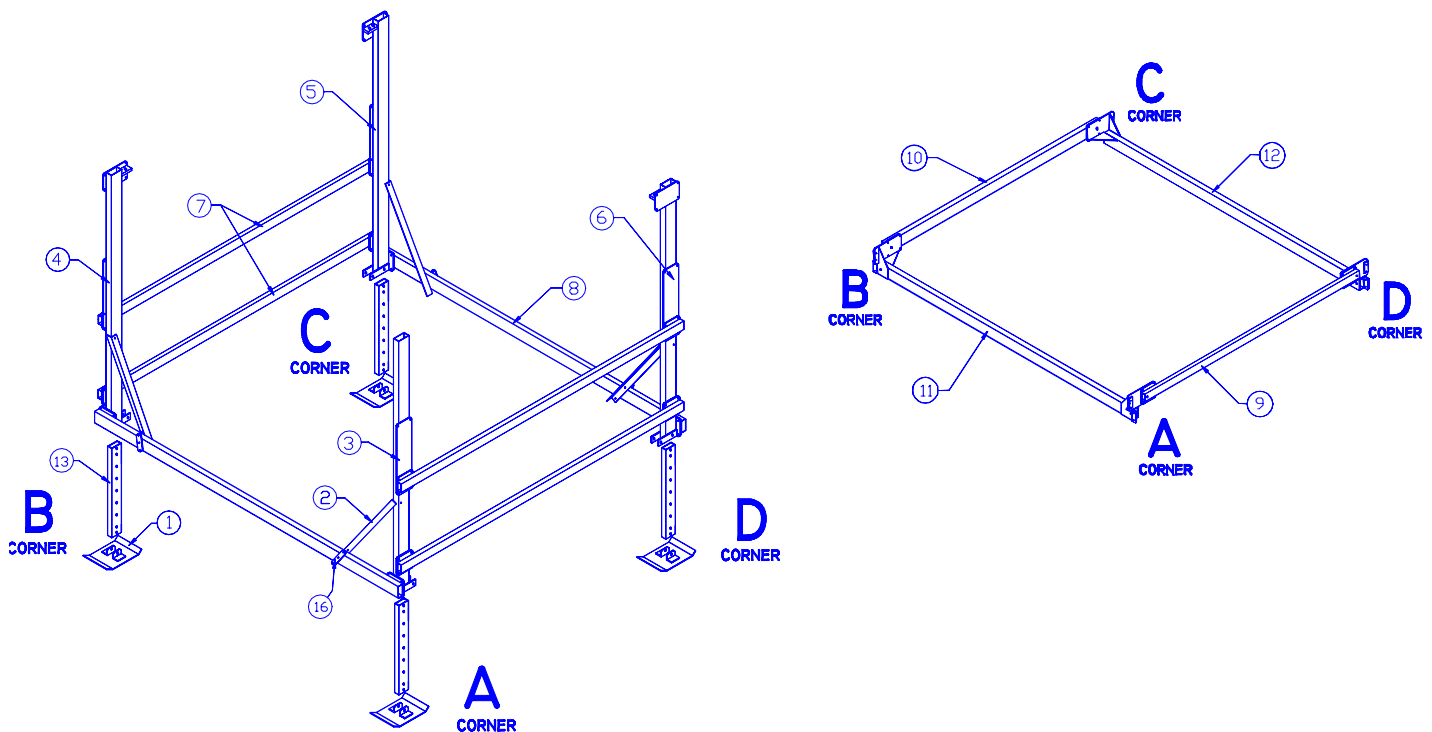

Figure 3-1.
Vertical Lift Frame & Platform Assembly

The lift may be placed on either side of your dock as shown in Figure 3-2. The winch is mounted onto vertical leg A.

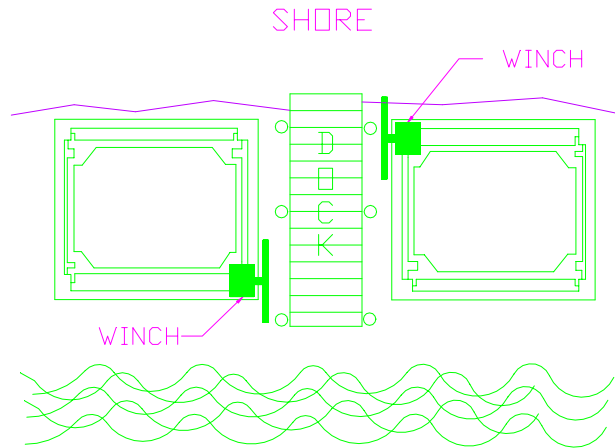

Figure 3-2
Lift / Dock Placement Options

Place one bag of hardware at each corner.



CAUTION:

INSERT ALL BOLTS FROM THE INSIDE OF THE LIFT TO PREVENT DAMAGE TO YOUR BOAT. THE NUTS FASTEN ONTO THE OUTSIDE FACE OF THE LIFT. THE ONLY BOLTS THAT MAY BE INSERTED FROM THE OUTSIDE OF THE LIFT ARE THOSE ON THE BOTTOM PARTS OF THE BRACES.

3.3 VERTICAL LEG ASSEMBLY

1. Refer to Figure 3-3. Fasten an extension leg onto each of the foot plates using supplied hardware. Insert these subassemblies into the bottoms of each of the vertical legs A, B, C, and D.
2. Connect the extension legs to the vertical legs with supplied VL Hitch Pins. Adjust the leg height according to water depth: the deeper the legs are in the water, the higher the vertical legs should be mounted onto the extension legs.

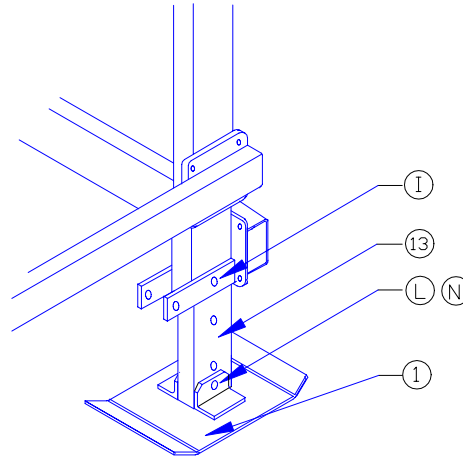

Figure 3-3
Vertical Leg Assembly

3.4 FRAME SIDE ASSEMBLY

1. Refer to Figure 3-4. Fasten a pair of short horizontal tubes between vertical legs A and D with hardware shown. DO NOT TIGHTEN.
2. Repeat the procedure for vertical legs B and C.
3. Lay the assembled sides down on the ground with the foot plates facing one another and aligned, about 9 feet apart.
4. Square the side assemblies by adjusting the verticals to achieve the same measured distance between them at both top and bottom. Refer to “Y” Dim. in Figure 3-6. Tighten all fasteners. Remeasure and align if necessary.

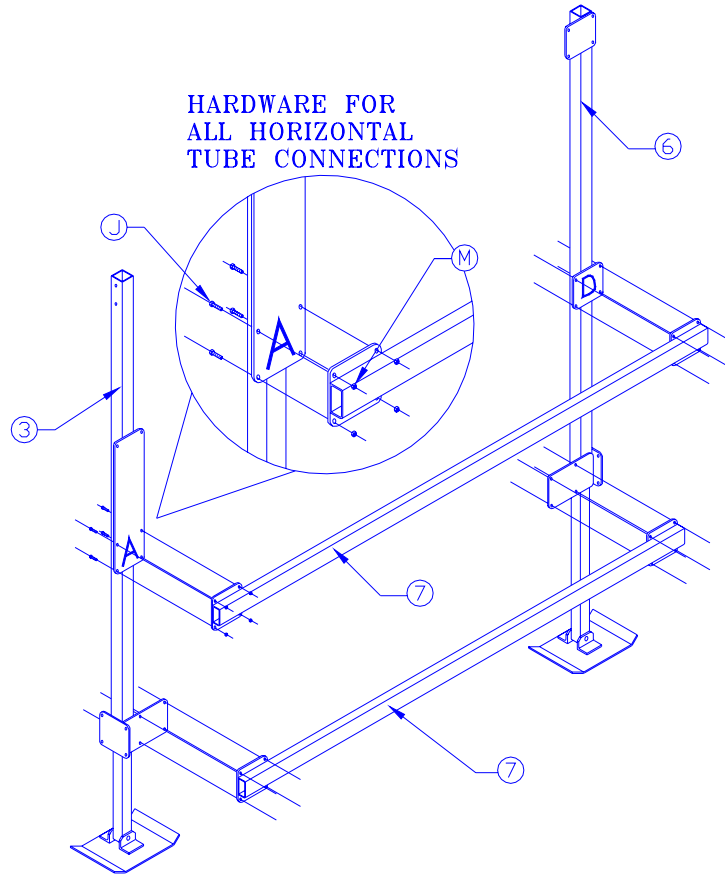

Figure 3-4
Frame Side Assembly

3.5 PLATFORM ASSEMBLY

1. Refer to Figure 3-5. Position both load tubes and spreader tubes on the ground as shown in the diagram.
2. Carefully remove the 5/8” hex nut and washers, if supplied, from each end of both spreader tubes, but DO NOT remove the bolts from the tubes. This will prevent the sheaves from falling out.
3. At each corner of the platform, align the holes in the spreader tube with the holes in the load tube. Fasten the tubes together. Then refasten the 5/8” hex nut and washers, if supplied.

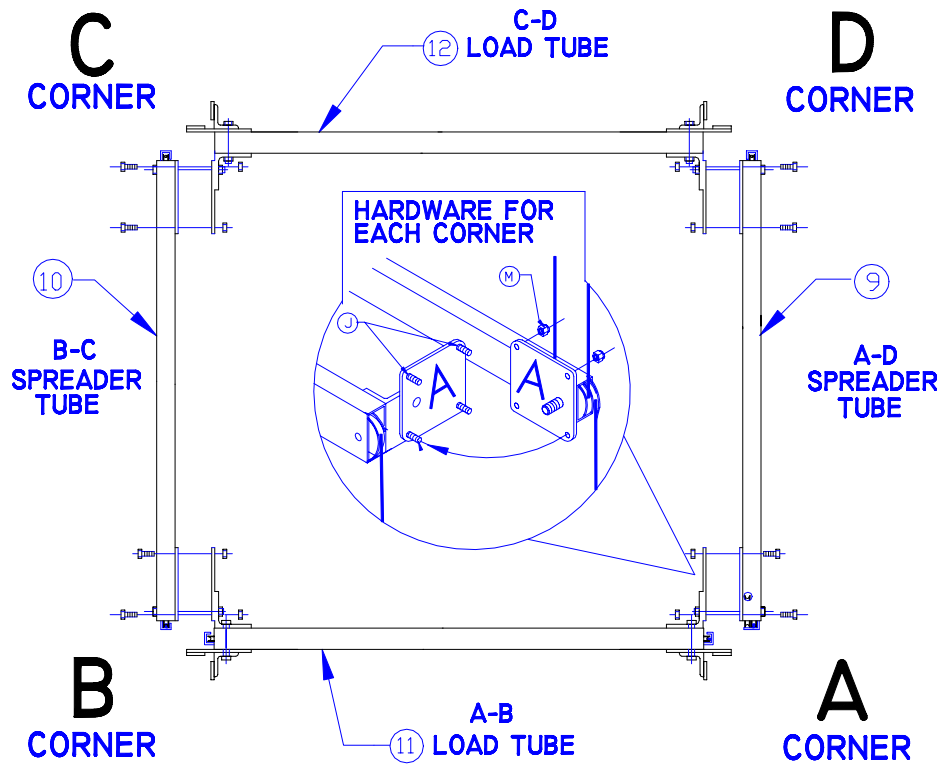

Figure 3-5
Platform Assembly – Top View

3.6 MOUNTING THE PLATFORM TO THE FRAME

1. Insure all platform fastenings are tight before mounting onto the frame.
2. Lift one of the frame sides and position it along a spreader tube side of the platform.
3. Place a platform corner onto each of the foot plates so that the frame side stands.
4. Repeat Steps 2 and 3 for the other side of the lift.



CAUTION:

THE LOAD AND SPREADER TUBES OF THE PLATFORM ARE ALREADY REEVED. WHEN PLACING THE ASSEMBLED PLATFORM INTO THE FRAME, INSURE THE CABLE LOOPS ARE PASSING OVER THE SHEAVES AND POINTING TOWARDS THE BOTTOM BRACKET OF EACH VERTICAL LEG. EQUIPMENT MALFUNCTION AND DAMAGE WILL RESULT IF THE PLATFORM IS NOT ORIENTED THIS WAY.

5. Fasten a long horizontal tube across each end to connect the two sides using hardware shown in Figure 3-4. **DO NOT TIGHTEN.**
6. Square the frame by adjusting the verticals to achieve the same measured distance between them at both top and bottom. Refer to “X” Dim. in Figure 3-6. Tighten all fasteners. Remeasure and align if necessary.

7. Install the eight (8) plastic caps provided onto the tops of the four vertical legs and the ends of the upper short horizontal tubes.

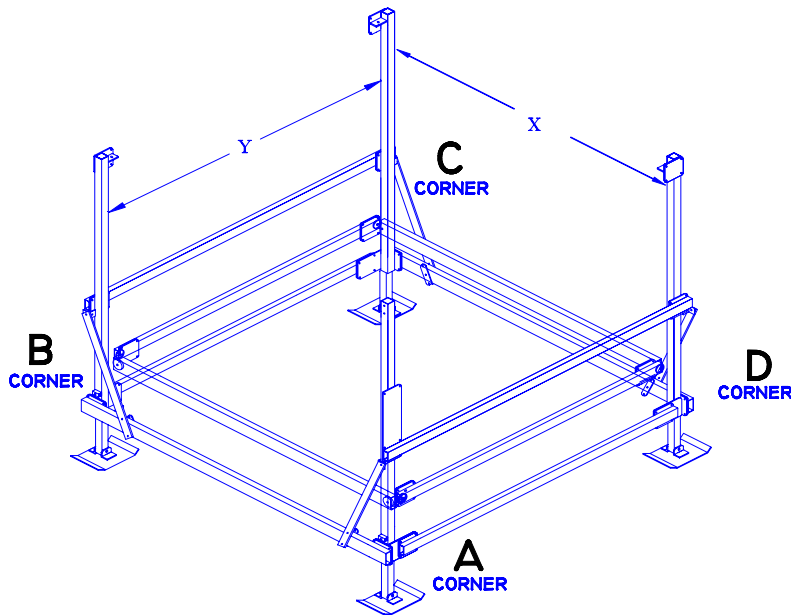

<u>MODEL</u>	<u>“X” DIM</u>	<u>“Y” DIM</u>
--------------	----------------	----------------

VL16092	92 IN.	90 IN.
---------	--------	--------

Note: Values shown are approx.

Figure 3-6
Frame Squaring Assembly / Table

3.7 MOUNTING THE LOWER DIAGONAL BRACES

1. Position a lower diagonal brace on the inside of vertical leg “B” as shown in Figure 3-7. Loosely fasten with hardware shown.
2. Position the opposite end along the long horizontal tube so that the tube is situated between the two holes located in the lower diagonal brace. Place a 3-hole plate onto the outside face of the horizontal tube.
3. Align the holes and fasten in place.
4. Repeat Steps 1 through 3 for each corner.



CAUTION:

THE FOUR LOWER DIAGONAL BRACES ARE MOUNTED ONLY TO THE TWO LONG HORIZONTAL TUBES. NEVER TRY TO MOUNT THESE BRACES TO ANY OF THE SHORT HORIZONTAL TUBES.

5. Insure the frame is square and that it satisfies the dimensions shown in Figure 3-6. About 1/4 to 1/2 inch difference between the upper and lower measurements is permitted.

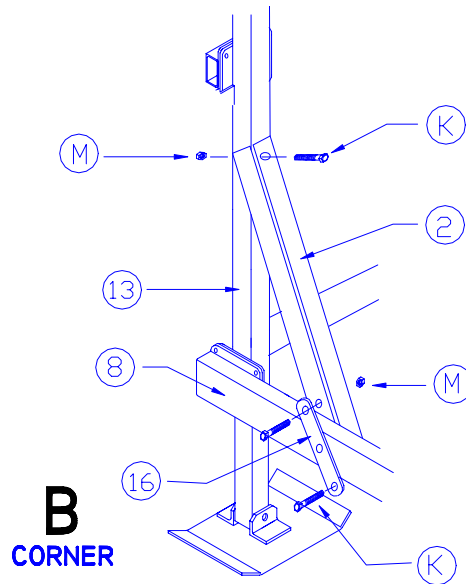

Figure 3-7
Lower Diagonal Brace Assembly

3.8 PLATFORM REEVING AND ADJUSTMENT

1. Position the platform near the bottom end of its lifting range. Insure the platform is level.
2. Refer to Figure 3-8. The load and spreader tubes are already reeved. Fasten the cable end loops to the bracket provided at the bottom of each of the four vertical legs.



CAUTION:

DO NOT “JAM TIGHT” THESE LOWER CABLE ANCHORS OR YOU WILL BREAK OFF THE BRACKET PLATES.



CAUTION:

WEAR HEAVY LEATHER GLOVES WHEN HANDLING WIRE ROPE. FAILURE TO DO THIS CAN CAUSE SERIOUS PERSONAL INJURY.

3. Using a 7/8” open-end wrench, tighten the cable studs opposite the cable end loops in the following order. The following step numbers correspond to the step numbers shown in Figure 3-8.

Step 1: Tighten down the nut to add tension to the B-C spreader tube cable.

Step 2: Tighten down the nut to add tension to the A-D spreader tube cable. Check that the B-C and A-D spreader tube cables are equal in tension and that the platform is level.

Step 3: Tighten down the nut to add tension to the first C-D load tube cable.

Step 4: Tighten down the nut to add tension to the second C-D load tube cable. Check that both C-D load tube cables are equal in tension and that the platform is level.

4. Add and tighten the jam nuts to the cable nuts to lock the position.
5. During operation, when the platform is being lifted, it is normal for the two cables in the C-D load tube to alternate from being tense to going slack. If you notice this, it is not necessary to further tighten down the nuts.

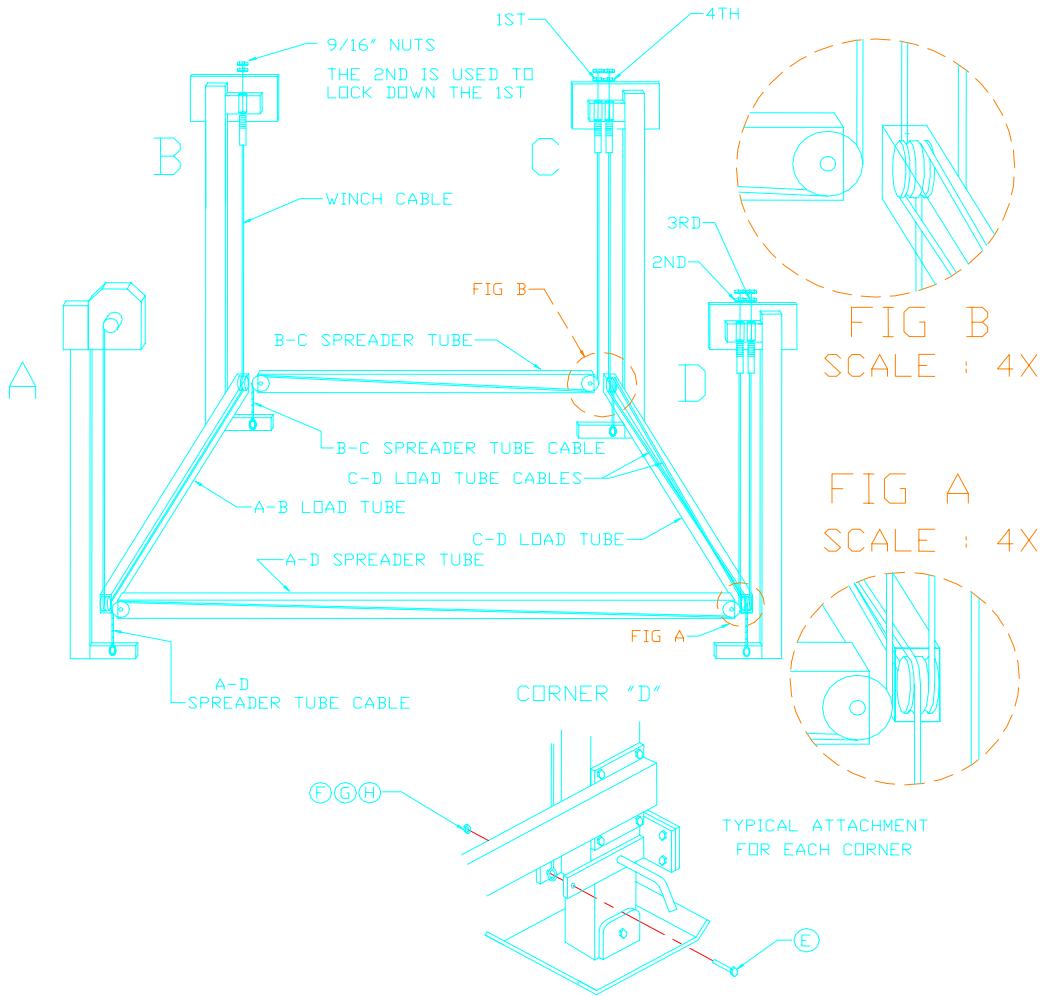

Figure 3-8
Cable Reeving & Adjustment

6. If the boat is not lifting level because the stern is lifting higher or lower than the bow, the spreader tube cables are not tight enough. Repeat the first two substeps under Step 3 above.

3.9 WINCH / HANDWHEEL MOUNTING

1. Refer to Figure 3-9. Attach winch to vertical leg "A" approximately 12 inches below the top of the leg. Lightly fasten with clamps. The handwheel adapter plate should be facing away from the lift as shown.
2. Attach the handwheel to the handwheel adapter plate.
3. Attach the spinner knob to the handwheel using the preassembled hardware. Select the hole that is most comfortable for lowering the lift.



CAUTION:

DO NOT USE THE SPINNER KNOB FOR LIFTING THE BOAT. THIS CAN CAUSE EQUIPMENT DAMAGE.

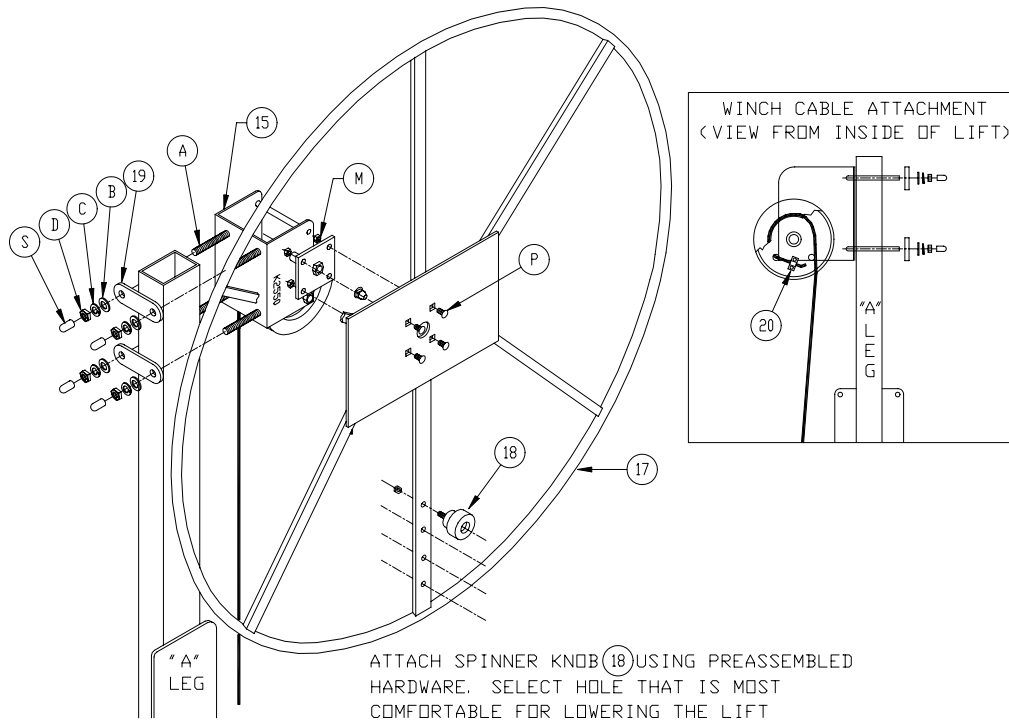

Figure 3-9
VL Handwheel / Winch Mounting and Reeving

3.10 REEVING THE WINCH

1. Refer to Figure 3-8. Attach the A-B load tube cable stud to vertical leg "B" .
2. Refer to Figure 3-9 Starting from the bottom of winch, reeve the cut end of cable between drum and winch mounting frame. Wrap cable over top of drum, through hole in RIGHT SIDE of drum flange and under cable clamp, with one inch of cable extending past clamp.
3. Fasten cable in place by tightening the nuts with lockwashers attached to clamp.
4. Adjust winch mounting height and cable stud attachment on vertical leg "B" to provide a **minimum of 3 wraps** of cable on drum before any load is lifted. Tightly fasten winch mounting hardware and jam nut on cable stud end when complete



WARNING:

WHEN REEVING THE WINCH, CLOCKWISE ROTATION OF THE HANDWHEEL MUST RAISE, NOT LOWER, THE PLATFORM. IF CLOCKWISE ROTATION OF THE HANDWHEEL LOWERS THE PLATFORM, YOU HAVE REEVED THE WINCH INCORRECTLY. AN UNCONTROLLED FREEWHEELING CAN BE TRIGGERED WITH THE WEIGHT OF A BOAT.

FREEWHEELING CAN CAUSE EQUIPMENT OR BOAT DAMAGE. HOWEVER, IF FREEWHEELING OCCURS, NEVER TRY TO STOP IT. THIS CAN CAUSE SERIOUS PERSONAL INJURY.

3.11 MOVING LIFT TO OPERATING POSITION

1. The following precautions must be observed when moving your lift for any reason:
 - a. Be sure of your footing.
 - b. Bend your knees and lift with your legs.
 - c. Hold the lift section close to your body when lifting.
2. After moving your lift to the operating position, insure that the frame is square and that the lift sets level.



CAUTION:

SEVERE OUT OF LEVEL INSTALLATION MAY CAUSE BINDING, RESULTING IN EQUIPMENT DAMAGE.



CAUTION:

FRAME MUST BE SQUARE TO PREVENT DAMAGE AND/OR IMPROPER FITTING OF CANOPY FABRIC IF SO EQUIPPED.

3. Verify frame is square by measuring the diagonal distance from the outside of frame corner to opposite corner. Repeat for alternate corners. The **difference between the two measurements shall not exceed 1/4 of an inch.**

Frame Diagonal Measurement Diagram
(Measure to Outside Corners)

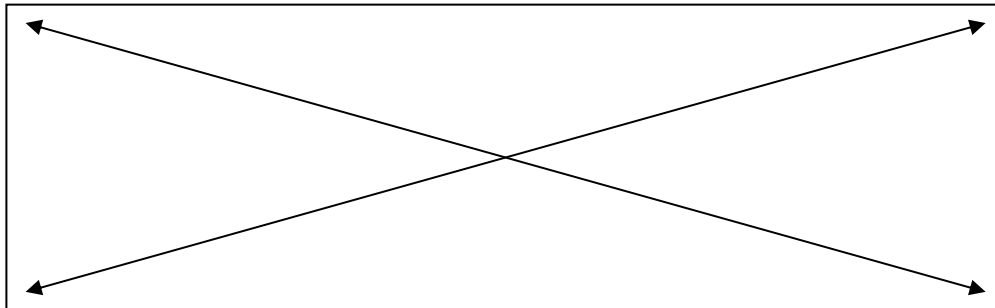

4 OPERATION

4.1 BEFORE OPERATING THE LIFT

1. Read and know the instructions and insure that everyone understands the proper operating procedure.
2. When using a power drive, understand the use of all controls and connections provided with it.
3. Follow the Pre-Lifting Checklist before operating.
4. Do not use the lift if it shows any signs of damage.
5. Insure that all bolts and nuts are fastened securely prior to operation.
6. Check that the winch is reeved properly. See reeving instructions in Chapter 3 of this manual.
7. Never try lifting anything other than a boat with this lift.



WARNING:

NEVER TRY TO USE THIS EQUIPMENT BEYOND ITS RATED CAPACITY. THIS CAN DAMAGE THE LIFT AND/OR BOAT RESULTING IN PERSONAL INJURY.

THE BOAT MUST BE PROPERLY POSITIONED ON THE LIFT BEFORE DOING ANY RAISING OR LOWERING. FAILURE TO DO THIS CAN CAUSE EQUIPMENT DAMAGE AND/OR PERSONAL INJURY.

8. Do not operate the lift under the influence of drugs, alcohol, or medication.
9. Completely remove any user or dealer installed locking devices.
10. Never try to lift or launch your boat in rough water conditions. This can damage your boat and/or the lift.

4.2 TESTING WINCH OPERATION

After the lift installation is complete, it is important that the winch functions properly. Test the winch operation as follows:

1. Raise the empty platform about one fourth the way up and release the handwheel. If the winch is functioning properly, the brake mechanism will hold the platform at any position. The handwheel or power drive must turn clockwise when raising the platform. The brake pawl must click, indicating that the brake is operative.



CAUTION:

IF YOU HAVE TO TURN THE HANDWHEEL COUNTERCLOCKWISE TO RAISE THE PLATFORM, YOU HAVE REEVED THE WINCH INCORRECTLY. YOU WILL IMMEDIATELY ENCOUNTER STRONG RESISTANCE WHICH CAN LEAD TO WINCH DAMAGE AND/OR CABLE BREAKAGE.

2. Repeat Step 1 in the half, three-quarters, and full lift positions.



WARNING:

IF THE HANDWHEEL STARTS TO FREELY SPIN DOWN FROM ANY OF THESE TEST POSITIONS, NEVER TRY TO STOP IT. DO NOT USE A LIFT IN THIS CONDITION.

3. Lower the empty platform to repeat steps 1 and 2 with your boat on the lift. The handwheel or power drive must turn counter-clockwise when lowering the platform. This counter-clockwise rotation allows the self-activating brake mechanism to stop the platform lowering as soon as the operator stops turning the handwheel. Make sure this brake mechanism is operative.
4. Contact your authorized dealer if the winch mechanism fails to perform as described in this section. Do NOT tamper with the winch mechanism.

4.3 RAISING AND LOWERING THE PLATFORM

1. Raise the platform by turning the handwheel clockwise. The self-activating brake mechanism will hold the platform at any desired height.
2. Platform should be raised a minimum of 1 foot between bottom of boat and highest potential water table height for your geographic area.
3. Lower the platform by turning the handwheel counterclockwise. Do not continue lowering the platform after the boat floats freely from the platform. Excessive winch cable slack may cause cable, lift, and winch damage.
4. Keep fingers and clothing clear of all moving parts. Keep people clear during operation of the lift.
5. Never allow people in the boat any time it is suspended above the water on the lift.



WARNING:

DO NOT STAND OR WALK ON THE LIFT PLATFORM WHILE IT IS IN ANY RAISED POSITION. THIS CAN CAUSE SERIOUS PERSONAL INJURY.

6. Check the lift periodically for frayed cables and/or binding pulleys.

4.4 SECURING LIFT WHEN NOT IN USE

At the end of operation, secure the lift to prevent unauthorized use. Proceed as follows:

1. Raise the platform to the desired height.
2. Padlock the handwheel to the post or lock out your power drive to prevent unauthorized use when your boat lift is unattended.

5 INSPECTION AND MAINTENANCE

5.1 GENERAL MAINTENANCE RULES

1. Do not allow persons other than authorized service personnel to repair this equipment.
2. If slings are used, inspect them for deterioration. Replace them immediately if they are worn.
3. Do not weld or otherwise modify the lift. Such alterations may weaken the structural integrity of the lift and invalidate your warranty.
4. Completely lower the lift before performing any type of maintenance or repair.



WARNING:

NEVER ALLOW ANYBODY TO WORK IN OR ON THE BOAT WHEN IT IS SUSPENDED ABOVE THE WATER ON THE LIFT. IF THE HANDWHEEL ON THE WINCH SHOULD START FREEWHEELING, SERIOUS INJURY OR DEATH COULD RESULT.

IF FREEWHEELING STARTS, NEVER TRY TO STOP IT. ALTHOUGH A SPIN DOWN OR “FREEWHEELING” CAN CAUSE LIFT OR BOAT DAMAGE, TRYING TO STOP FREEWHEELING CAN CAUSE SERIOUS PERSONAL INJURY.

5.2 WIRE ROPE INSPECTION PROCEDURE

Inspect the wire rope prior to each use for signs of wear, damage, or pinching. Inspect the entire wire rope working length. Thoroughly inspect the rope sections that pass over sheaves or drums, or that make opposing turns. Inspect wire rope and end attachments carefully. While inspecting, examine sheaves, guards, guides, drums, flanges, and other surfaces contacting wire rope during operation. Correct any condition harming the rope in use or other damage or worn surfaces at this time.



CAUTION:

WEAR HEAVY LEATHER GLOVES WHEN HANDLING WIRE ROPE. INSUFFICIENT HAND PROTECTION WHEN HANDLING WIRE ROPE CAN CAUSE PERSONAL INJURY.

Remove and immediately replace wire rope with one or more of the following defects:

1. Corrosion
2. Broken wires:
 - (a) One or more valley breaks. A valley break is a wire break occurring in the valley between two adjacent strands.
 - (b) Six randomly distributed broken wires in one rope lay. A rope lay is the length of rope along which one strand makes a complete revolution around the rope. See Figure 5-1. Keeping the rope clean and wound evenly on the winch drum will increase its life and efficiency.
3. Abrasion: Scrubbing, flattening or peening causing loss of more than one-third of the original diameter of the outside wires.
4. Kinking: Severe kinking, crushing, bird caging or other damage causing distortion of the rope structure. Bird caging is a bulging in the cable caused by the individual wires becoming untwisted. This untwisting of individual wires is usually caused by impact loading on the cable (such as a sudden stop).

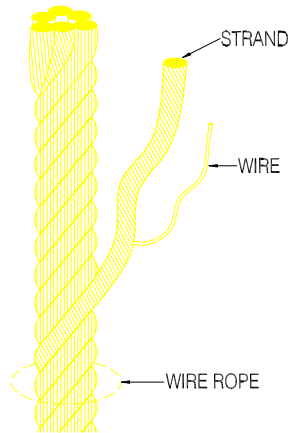

Figure 5-1
Wire Rope Components

5. Heat damage: Evidence of any heat damage caused by a torch or by contact with electrical wires.
6. Reduction of more than 1/64 inch from a nominal 5/16-inch or less diameter cable. Reduction of more than 1/32 inch from a nominal 3/8-inch to 1/2-inch diameter cable.

5.3 ANNUAL INSPECTION

At least once a year, the lift must be thoroughly inspected using the following procedure.



WARNING:

DO NOT ALLOW ANYBODY TO USE THE LIFT UNTIL THIS MAINTENANCE IS COMPLETED.

1. Tighten all bolts.
2. Check the sheaves to insure that they spin freely. If they bind, replace them immediately.
3. Check frame thoroughly for defects.
4. Perform the winch maintenance as described in Section 5.4.

5.4 ANNUAL WINCH MAINTENANCE

1. The winch maintenance schedule must be followed to avoid possible equipment failure or personal injury.
2. Before removing the winch cover to inspect or work on the winch, be sure the platform is completely lowered. Do not reach through the wheel and manipulate any of the winch mechanisms when the platform is raised.
3. Grease the chains and bearing inside winch.
4. Grease cables and sheave bearings.
5. Grease winch hub.

6. Remove acorn nut on handwheel and turn counterclockwise to remove wheel to clearly expose the input shaft threads.
7. Grease threads; avoid contaminating fibrous brake disk.
8. Thread wheel back on until brake pawl begins clicking. Reinstall and tighten acorn nut.



WARNING:

AFTER EVERY WINCH MAINTENANCE, TEST THE WINCH MECHANISM AS DESCRIBED IN CHAPTER 4 BEFORE LETTING ANYONE USE THE LIFT.

5.5 STORAGE PROCEDURE

1. Position boat on platform so the lower unit of the motor is against the optional motor stop (if used).
2. A boat that has water in it from a rain storm could exceed the recommended weight capacity for the lift. Just 1 gallon of water weighs over 8 pounds. Be sure to remove the plug while the boat is up on the lift. Make sure you replace the plug prior to launching your boat.
3. Protect your lift as far as possible from damage caused by environmental factors such as airborne fallout, chemicals, tree sap, and weather hazards.
4. Never use the lift to hang or store any auxiliary equipment such as boating hardware.
5. Do not allow anyone to swim or play near the lift at any time.
6. Padlock the handwheel to the post and disconnect the power to any electric motor when your boat lift is unattended. Never assume you will find the lift in the same condition that you left it.

6 TROUBLESHOOTING

The following chart is intended to assist with troubleshooting your vertical lift. While not all inclusive, the chart outlines the most common causes of a problem and the recommended course of action.

SYMPTOM	CAUSE AND CORRECTIVE ACTION
Winch resists platform raising.	<p>Winch has been reeved incorrectly—winch must turn clockwise to raise platform. See Section 3.10.</p> <p>Sheaves binding—inspect/lubricate/replace.</p> <p>Winch cable is rubbing against the winch frame—repeat winch reeving if necessary following Section 3.10.</p>
Winch fails to hold the platform in a given position as described in the test procedure of Section 4.2	Contact your authorized dealer—tampering with the winch mechanism can cause equipment damage that may invalidate your warranty.
Winch is operating properly, but platform raising is either difficult or impossible.	<p>Platform is binding because frame is either not square or not set level in the water—refer to Sections 3.6 and 3.7.</p> <p>One or more wires are broken—refer to Section 5. 2</p> <p>Sheaves binding—inspect/lubricate/replace.</p> <p>One or more cables are excessively worn—replace as required and follow monthly wire rope inspection procedure described in Section 5.2.</p> <p>Load exceeds rated capacity— Reduce load weight as needed.</p> <p>User or dealer installed locking devices are in place—remove these.</p> <p>Auxiliary equipment such as boating hardware is being improperly hung on lift—remove this equipment permanently.</p>
Boat is not lifting level—stern is lifting higher or lower than the bow.	<p>Frame is not level in the water—relocate pin connections between the adjustable and vertical legs.</p> <p>Frame is level in the water but spreader tube cables are not tight enough—</p> <ol style="list-style-type: none"> 1. Tighten down the cable stud nut to add tension to the B-C spreader tube cable. 2. Tighten down the cable stud nut to add tension to the A-D spreader tube cable. Check that the B-C and A-D spreader tube cables are equal in tension and that the platform is level.
Boat shifts position when operating the lift.	Boat is not properly secured on the lift—failure to properly secure boat can cause equipment damage and/or serious personal injury.

<p>Lowering operation triggers a “freewheeling” of the handwheel.</p>	<p>Winch has been reeved incorrectly—winch must turn counterclockwise to lower the platform. See Section 3.10.</p> <p>Unauthorized brake pawl release has occurred—do not try to correct this yourself. Contact your authorized dealer immediately.</p>
---	---



WARNING:

NEVER RELEASE THE BRAKE PAWL OF THE WINCH. THIS CAN VOID YOUR WARRANTY AND TRIGGER AN UNCONTROLLED SPIN-DOWN OR “FREEWHEEL” OF THE HANDWHEEL. FREEWHEELING CAN CAUSE EQUIPMENT OR BOAT DAMAGE. IF FREEWHEELING OCCURS, NEVER TRY TO STOP IT, AS THIS CAN CAUSE SERIOUS PERSONAL INJURY.

<p>Lowest platform position is too high or low relative to the water.</p>	<p>Connections between the vertical and adjustable legs need readjusting—do this with the Item I leg pin shown in Figure 3-3.</p>
<p>Boat is getting damaged during raising or lowering operations.</p>	<p>One or more bolts are installed improperly--all bolts except those on the bottom parts of the braces must be installed from the inside of the lift.</p>

7 PARTS LISTS

Each item number or letter in the following parts lists can be matched with the item number or letter referred to in both the text and illustrations of Sections 3.1 through 3.9 of Chapter 3, Installation and Setup.

7.1 #3616000 VL 16092 BOAT LIFT BUNDLES

7.1.1 #3616020 VL 16092 Bundle 1 of 2

REF #	PART #	QTY	DESCRIPTION
1	3603809	4	VL FOOT PLATE ASSY
2	3603832	4	VL LOWER DIAGONAL BRACKET
3	3608003	1	VL VERTICAL LEG (A) ASSY
4	3608011	1	VL VERTICAL LEG (B) ASSY
5	3608005	1	VL VERTICAL LEG (C) ASSY
6	3608007	1	VL VERTICAL LEG (D) ASSY

7.1.2 #3616021 VL 16092 Bundle 2 of 2

REF #	PART #	QTY	DESCRIPTION
7 & 8	3603823	6	VL HORIZONTAL 100"
9	3603779	1	VL SPREADER TUBE ASSY (AD)
10	3603777	1	VL SPREADER TUBE ASSY (BC)
11	3616040	1	VL LOAD TUBE ASSY A-B
12	3616039	1	VL LOAD TUBE ASSY C-D

7.2 VL EXTENSION LEGS

REF #	PART #	QTY	DESCRIPTION
13	3623831	As ordered	VL EXTENSION LEGS 29 1/2" (PR.)
"	3623911	"	VL EXTENSION LEGS 4' W / BRACING (PR.)
"	3623914	"	VL EXTENSION LEGS 6' W / BRACING (PR.)
"	3623916	"	VL EXTENSION LEGS 8' W / BRACING (PR.)
"	3623918	"	VL EXTENSION LEGS 10' W / BRACING (PR.)

7.3 #3679355 VL BUNK CARTON OF PARTS

REF #	PART #	QTY	DESCRIPTION
	3603936	4	VL CRADLE BRACKET
	3603937	4	VL CRADLE BRACKET FLAT
	3603938	4	VL CRADLE BRACKET ANGLE
	3605977	1	VL BUNK BAG OF BOLTS

7.4 #3603778 VL BUNK BUNDLE

REF #	PART #	QTY	DESCRIPTION
	3605916	2	VL BUNK ASSY

7.5 #3616033 VL 16092 CARTON OF PARTS

REF #	PART #	QTY	DESCRIPTION
15	3638145	1	WINCH K2550 W / HOLES
20	3703142	1	WINCH CABLE CLAMP KIT
	3616087	1	VL 16092 FULTON WINCH BAG OF BOLTS consisting of:
19	3603835	2	VL 2" WINCH BOLT PLATE
S	6408069	4	CAP THREAD 11/32 X 1/2" LONG
A	5898100	2	U-BOLT SQ. BD 3/8 X 2 1/8 X 5 5/8" LONG
B	5896406	4	3/8 WASHER SAE
C	5806243	4	3/8 WASHER SPLIT LOCK
D	5896377	4	3/8 NUT HEX

7.6 #3655255 VL HARDWARE

REF #	PART #	QTY	DESCRIPTION
16	9703593	4	VL THREE HOLE PLATE
I	3629961	1	VL HITCH PIN SET (4 PINS)
	6403795	4	PLASTIC CAP-1 1/2 X 3 X 1/8" TUBE
	6403794	4	PLASTIC CAP-2 X 4 X 1/8" TUBE
	3665510	4 PKGS.	VL CORNER HARDWARE BAG OF BOLTS consisting of:
J	5896247	17	3/8-16 X 1" HHCS
K	5897017	3	3/8-16 X 3 1/4" HHCS
L	5896288	1	1/2-13 X 3" HHCS
M	5897016	20	3/8-16 NYLOCK NUT
N	5897018	1	1/2-13 NYLOCK NUT
	3606541	1 PKG.	VL CABLE HARDWARE BAG OF BOLTS consisting of:
E	5896290	4	1/2-13 X 3 1/2" HHCS
H	5896379	4	1/2-13 NUT HEX
F	5896400	4	1/2 WASHER SAE
G	5806244	4	1/2 WASHER SPLIT LOCK
O	5896397	10	9/16-12 HEX NUT

7.7 #3703811 VL HANDWHEEL 4'

REF #	PART #	QTY	DESCRIPTION
17	3703803	1	VL HANDWHEEL 4'
18	3671010	1	KNOB ASSEMBLY SPINNER HANDWHEEL
	3703801	1	VL HANDWHEEL BAG OF BOLTS consisting of:
P	5896217	4	3/8-16 X 1 1/4" CARRIAGE BOLT
M	5897016	4	3/8-16 NYLOCK NUT

LIMITED WARRANTY

REIMANN & GEORGER CORPORATION MARINE PRODUCTS

RGC Marine products, hereafter referred to as the “Manufacturer”, extends this limited warranty to the original purchaser of this product. The original purchaser, hereinafter referred to as the “Buyer”, is defined as the first legal owner of this product other than an authorized distributor or dealer who has bought the product from the Manufacturer for resale to the public. **The Buyer must complete and return the Warranty Registration section of the provided Warranty Card to make this limited warranty effective.**

CONSUMER PRODUCT PROVISIONS

I. ARTICLE I—CONSUMER PRODUCT PROVISIONS: THE FOLLOWING PROVISIONS SHALL BE APPLICABLE IF THIS PRODUCT IS BEING PURCHASED FOR PERSONAL, FAMILY OR HOUSEHOLD PURPOSES.

THE CONSUMER PRODUCT PROVISIONS CONTAINED IN THIS ARTICLE I SHALL APPLY UNLESS THIS PRODUCT IS BEING PURCHASED SOLELY FOR COMMERCIAL OR INDUSTRIAL USE, IN WHICH EVENT THE PROVISIONS CONTAINED IN ARTICLE II BELOW SHALL APPLY AND THE PROVISIONS CONTAINED IN THIS ARTICLE I SHALL BE INAPPLICABLE.

A. 2-YEAR LIMITED WARRANTY

The Manufacturer warrants to the Buyer that all supplied parts shall be free of defects in material and workmanship for a period of two (2) years from date of original purchase. This limited warranty covers the cost of all parts and labor needed to repair any item that is found to be defective in material and workmanship. Items covered include cables, sheaves, chains, motors, reducers, switches, control panels and ground fault circuit interrupters.

B. 15-YEAR LIMITED WARRANTY ON VL/PL SERIES ALUMINUM FRAME EXTRUSION

The Manufacturer warrants to the Buyer that the frame and extrusions shall be free of defects in material and workmanship for a period of fifteen (15) years from date of original purchase. This limited warranty covers the cost of all parts and labor needed to repair any item that is found to be defective in material and workmanship.

C. MANUFACTURER’S OBLIGATIONS

The Manufacturer’s sole obligation under either of these limited warranties is the replacement or repair, at the Manufacturer’s discretion, of parts found to be defective.

D. NO SPECIAL, INCIDENTAL OR CONSEQUENTIAL DAMAGES

IN NO EVENT SHALL THE MANUFACTURER BE LIABLE TO THE BUYER OR ANY PERSON FOR ANY INDIRECT, SPECIAL, INCIDENTAL, OR CONSEQUENTIAL LOSSES OR DAMAGES CONNECTED WITH THE USE OF THE PRODUCT UNDER WARRANTY. SUCH DAMAGES FOR WHICH THE MANUFACTURER SHALL NOT BE RESPONSIBLE INCLUDE, BUT ARE NOT LIMITED TO, LOST TIME AND CONVENIENCE, LOSS OF USE OF THE PRODUCT, THE COST OF A PRODUCT RENTAL, COSTS OF GASOLINE, TELEPHONE, TRAVEL, OR LODGING, THE LOSS OF PERSONAL OR COMMERCIAL PROPERTY, AND THE LOSS OF REVENUE.

Some States do not allow the exclusion or limitation of incidental or consequential damages, so the above limitation or exclusion may not apply to you.

E. NO LIABILITY IN EXCESS OF PURCHASE PRICE

IN NO EVENT SHALL THE MANUFACTURER'S OBLIGATIONS UNDER THIS LIMITED WARRANTY EXCEED THE PURCHASE PRICE OF THE PRODUCT.

F. NO EXTENSION OF STATUTE OF LIMITATIONS

ANY REPAIRS PERFORMED UNDER EITHER OF THESE WARRANTIES SHALL NOT IN ANY WAY EXTEND THE TWO-YEAR AND FIFTEEN-YEAR STATUTES OF LIMITATIONS CONTAINED IN THIS LIMITED WARRANTY.

G. PROCEDURE FOR WARRANTY PERFORMANCE

If the product fails to perform to the Manufacturer's specifications, the Buyer must contact the dealer from whom the product was purchased. The Buyer must provide the dealer with the applicable model and serial numbers, the date of purchase, and the nature of the problem.

H. PREAPPROVAL OF LABOR COSTS

All labor costs related to a dealer's performance of the warranty obligations under this limited warranty must be pre-approved by Reimann & Georger Corporation Marine Products.

I. NO OTHER EXPRESS WARRANTIES

THE MANUFACTURER IS NOT SUBJECT TO ANY EXPRESS WARRANTIES OTHER THAN THOSE SET FORTH ABOVE.

J. LIMIT ON DURATION OF IMPLIED WARRANTIES

THE DURATION OF ANY IMPLIED WARRANTIES UNDER APPLICABLE STATE LAW RELATING TO THE PURCHASE OF THIS PRODUCT SHALL BE LIMITED TO A PERIOD OF TWO (2) YEARS FROM THE DATE OF PURCHASE.

Some States do not allow limitations on how long an implied warranty lasts, so the above limitations may not apply to you.

K. QUESTIONS REGARDING LIMITED WARRANTY

Any questions regarding this limited warranty or the procedure which the consumer should follow in order to obtain performance of any warranty obligation may be addressed to either the dealer from whom this product is purchased or to Reimann & Georger Corporation Marine Products, P.O. Box 681, Buffalo, NY 14240.

L. EXCLUSIONS FROM LIMITED WARRANTY. THIS LIMITED WARRANTY DOES NOT COVER ANY OF THE FOLLOWING:

1. Equipment which has been abused, damaged, used beyond rated capacity, or which is damaged or has defects caused by repairs or service completed by persons other than authorized service personnel.
2. Costs of repairing damage caused by environmental factors which include, but are not limited to, airborne fallout, chemicals, tree sap, salt, ocean spray, and water hazards.
3. Damage caused by acts of God which include, but are not limited to, hailstorms, windstorms, tornadoes, sandstorms, lightning, floods, and earthquakes.

4. Damage under conditions caused by fire or accident, by abuse or negligence, by improper installation, by misuse, by incorrect operation, by “normal wear and tear”, by improper adjustment or alteration, by alterations not done by the Manufacturer, or by failure of product parts from such alterations.
5. Costs of repairing damage caused by poor or improper maintenance, costs of normally scheduled maintenance, or the cost of replacing any parts unless done as the result of a repair covered by your two-year limited warranty.
6. Costs of modifying the product in any way once delivered to the Buyer, even if such modifications were added as a production change on other products made after the Buyer’s product was built.

M. RIGHT TO MODIFY PRODUCT

The Manufacturer has the right to modify this product at any time without incurring any obligation to make the same or similar modifications on products previously purchased.

N. NO AUTHORITY TO ALTER WARRANTY

No agent, representative, distributor or dealer has any authority to alter the terms of this warranty in any way.

O. SPECIFIC LEGAL RIGHTS

This warranty gives you specific legal rights and you may also have other rights which vary from State to State.

COMMERCIAL PRODUCT PROVISIONS

II. ARTICLE II—COMMERCIAL PRODUCT PROVISIONS: THE FOLLOWING PROVISIONS SHALL BE APPLICABLE ONLY IF THIS PRODUCT IS BEING PURCHASED SOLELY FOR COMMERCIAL OR INDUSTRIAL USE. IF THIS PRODUCT IS BEING PURCHASED FOR PERSONAL, FAMILY OR HOUSEHOLD PURPOSES, THE PROVISIONS CONTAINED IN THIS ARTICLE II SHALL NOT BE APPLICABLE AND THE PROVISIONS CONTAINED IN ARTICLE I ABOVE SHALL APPLY.

A. 1-YEAR LIMITED WARRANTY

The Manufacturer warrants to the Buyer that all supplied parts shall be free of defects in material and workmanship for a period of one (1) year from date of original purchase. This limited warranty covers the cost of all parts and labor needed to repair any item that is found to be defective in material and workmanship. Items covered include cables, sheaves, chains, motors, reducers, switches, control panels and ground fault circuit interrupters.

B. 5-YEAR LIMITED WARRANTY ON VL/PL SERIES ALUMINUM FRAME EXTRUSION

The Manufacturer warrants to the Buyer that the frame and extrusions shall be free of defects in material and workmanship for a period of five (5) years from date of original purchase. This limited warranty covers the cost of all parts and labor needed to repair any item that is found to be defective in material and workmanship.

C. MANUFACTURER'S OBLIGATIONS

The Manufacturer's sole obligation under either of these limited warranties is the replacement or repair, at the Manufacturer's discretion, of parts found to be defective.

D. NO SPECIAL, INCIDENTAL, OR CONSEQUENTIAL DAMAGES

IN NO EVENT SHALL THE MANUFACTURER BE LIABLE TO THE BUYER OR ANY PERSON FOR ANY INDIRECT, SPECIAL, INCIDENTAL, OR CONSEQUENTIAL LOSSES OR DAMAGES CONNECTED WITH THE USE OF THE PRODUCT UNDER WARRANTY. SUCH DAMAGES FOR WHICH THE MANUFACTURER SHALL NOT BE RESPONSIBLE INCLUDE, BUT ARE NOT LIMITED TO, LOST TIME AND CONVENIENCE, LOSS OF USE OF THE PRODUCT, THE COST OF A PRODUCT RENTAL, COSTS OF GASOLINE, TELEPHONE, TRAVEL, OR LODGING, THE LOSS OF PERSONAL OR COMMERCIAL PROPERTY, AND THE LOSS OF REVENUE.

E. NO LIABILITY IN EXCESS OF PURCHASE PRICE

IN NO EVENT SHALL THE MANUFACTURER'S OBLIGATIONS UNDER THIS LIMITED WARRANTY EXCEED THE PURCHASE PRICE OF THE PRODUCT.

F. NO EXTENSION OF STATUTE OF LIMITATIONS

ANY REPAIRS PERFORMED UNDER EITHER OF THESE WARRANTIES SHALL NOT IN ANY WAY EXTEND THE RESPECTIVE STATUTES OF LIMITATIONS CONTAINED IN THIS LIMITED WARRANTY.

G. WAIVER OF OTHER WARRANTIES

THESE EXPRESS WARRANTIES ARE IN LIEU OF AND EXCLUDE ANY AND ALL OTHER WARRANTIES, EXPRESS OR IMPLIED, INCLUDING, BUT NOT LIMITED TO, THE IMPLIED WARRANTIES OR MERCHANTABILITY AND FITNESS FOR A PARTICULAR PURPOSE.

H. PROCEDURE FOR WARRANTY PERFORMANCE

If the product fails to perform to the Manufacturer's specifications, the Buyer must contact the dealer from whom the product was purchased. The Buyer must provide the dealer with the applicable model and serial numbers, the date of purchase, and the nature of the problem.

I. PREAPPROVAL OF LABOR COSTS

All labor costs related to a dealer's performance of the warranty obligations under this limited warranty must be pre-approved by Reimann & Georger Corporation Marine Products.

J. EXCLUSIONS FROM WARRANTY. THIS LIMITED WARRANTY DOES NOT COVER ANY OF THE FOLLOWING:

1. Equipment which has been abused, damaged, used beyond rated capacity, or which is damaged or has defects caused by repairs or service completed by persons other than authorized service personnel.
2. Costs of repairing damage caused by environmental factors which include, but are not limited to, airborne fallout, chemicals, tree sap, salt, ocean spray, and water hazards.
3. Damage caused by acts of God which include, but are not limited to, hailstorms, windstorms, tornadoes, sandstorms, lightning, floods, and earthquakes.
4. Damage under conditions caused by fire or accident, by abuse or negligence, by improper installation, by misuse, by incorrect operation, by "normal wear and tear", by improper adjustment or alteration, by alterations not done by the Manufacturer, or by failure of product parts from such alterations.
5. Costs of repairing damage caused by poor or improper maintenance, costs of normally scheduled maintenance, or the cost of replacing any parts unless done as the result of a repair covered by your one-year limited warranty.
6. Costs of modifying the product in any way once delivered to the Buyer, even if such modifications were added as a production change on other products made after the Buyer's product was built.

K. RIGHT TO MODIFY PRODUCT

The Manufacturer has the right to modify this product at any time without incurring any obligation to make the same or similar modifications on products previously purchased.

L. NO AUTHORITY TO ALTER WARRANTY

No agent, representative, distributor, or dealer has any authority to alter the terms of this warranty in any way.

M. SPECIFIC LEGAL RIGHTS

This warranty gives you specific legal rights, and you may also have other rights which vary from State to State.