

BH-USA
Coastal Series™

Aluminum Boat House Lift

8K and 4K Side mount

INSTALLATION MANUAL



Coastal
Series™
by BH-USA

- Made in the USA !
- Beltless Drives !
- All Aluminum !
- No Weld Cradles !

BH-USA - Longview Texas

800-259-8175

Fax (903) 758-3646

www.bh-usa.com

BH-USA Coastal Series Lifts

BH-USA has been manufacturing hoist and boat lifts since 1979 in Longview Texas, as one of the nations oldest and most trusted hoist and lift manufacture, we know that your selection of the BH-USA Coastal Series overhead lift is the right choice.

The BH-USA overhead coastal lift is the most advanced, easy to use and most minimal maintenance overhead lift available. The light weight simple design makes this the number one choice for installers and do-it-yourself installers in the nation.

Before you begin.

The BH-USA Coastal Series overhead lift is intended to be mounted on top of wood stringers attached to pilings. The wood stringers and pilings must be able to carry the load of the lift and boat to be lifted. Consult your local boat house builder for recommended minimum pile sizes and stringer sizes. BH-USA used 8" pilings with single 2 x 12" stringers for engineering and testing. The BH-USA Coastal Series Lifts come with Aluminum Overhead beams. Pilings and Stringers are responsibility of builder or customer.

Shipping

BH-USA Coastal Series overhead lifts ship complete in a single 13ft by 2ft x 2ft wood crate that is heat shrink wrapped. All Lifts ship freight and will be the customers responsibility to unload lift from truck. Before you sign for the lift insure that the white heat shrink wrap has not been broken or torn and that the BH-USA part number label with UPC code is still present. This will insure that all items needed for your installation are present. Each item is listed in the back of this guide for each lift as a reference.

Lifts covered in this guide

8,000 lb Coastal Series Side Mount with V-Hull Cradle
8,000 lb Coastal Series Side Mount with Pontoon Boat Cradle*
8,000 lb Coastal Series Side Mount with Tri-Toon Boat Cradle*
8,000 lb Coastal Series Side Mount with slings

4,000 lb Coastal Series Side Mount with V-Hull Cradle
4,000 lb Coastal Series Side Mount with Pontoon Boat Cradle*
4,000 lb Coastal Series Side Mount with Tri-Toon Boat Cradle*
4,000 lb Coastal Series Side Mount with slings

- Pontoon boat cradles do not include the wood for the bunks. V-Hull cradles come with aluminum bunks standard.

All lifts come standard with galvanized drive pipes.

STEP 1: Setting up beams and brackets

Install Beams and Brackets as shown

Beams come 12'-6" long and are easily cut for better fitment in slip.

For 8000 lb compounded kits you will have (4) slide on dead man brackets, straight line 4000 lb kits will not use these.

8K (2) slide on pulley brackets followed by (2) dead man brackets. Pulley brackets on inside.

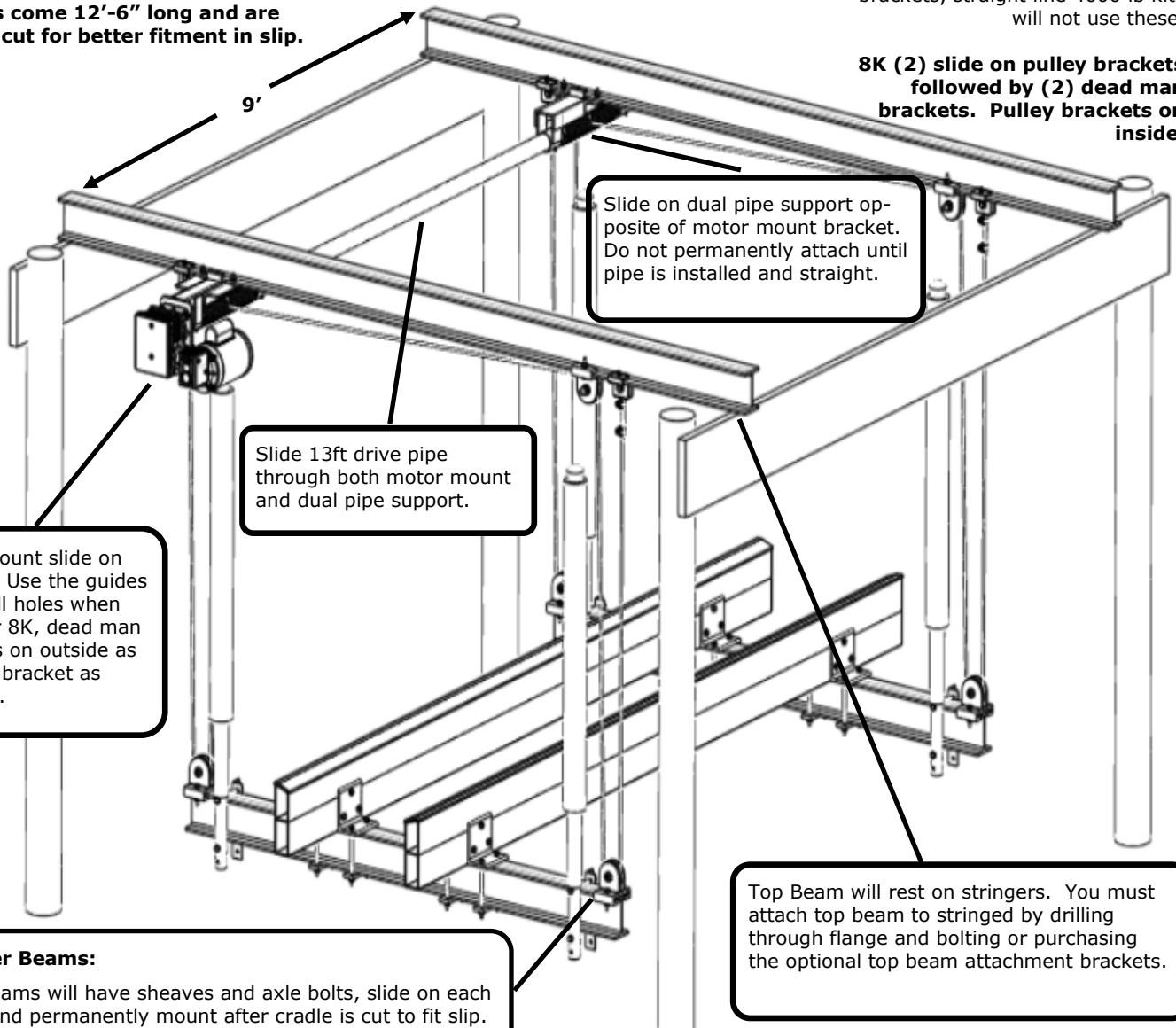

Slide 13ft drive pipe through both motor mount and dual pipe support.

Slide on dual pipe support opposite of motor mount bracket. Do not permanently attach until pipe is installed and straight.

Motor Mount slide on bracket. Use the guides then drill holes when set. For 8K, dead man brackets on outside as close to bracket as possible.

Lower Beams:
8K beams will have sheaves and axle bolts, slide on each end and permanently mount after cradle is cut to fit slip. 4K beams will use the same pulley brackets but will not have sheaves.

Top Beam will rest on stringers. You must attach top beam to stringed by drilling through flange and bolting or purchasing the optional top beam attachment brackets.

Note: It is recommended that you scaffold the pilings to assist in installing the lower cradle beams.

No alterations should be made to this lift other than cutting the beams to fit better

Top beams should not be placed any further than 9ft apart, placing beams further apart will effect overall rating

Pipe must be straight and plum and easily turned by hand when installed between the two brackets

Don't forget to insert cable winder before you slide pipe in!

Pipe is pre-drilled for hoist but will have to be drilled for cable

Dead man brackets should be placed as close to sheave housings and pipe supports as possible. Cable on compounded lifts should not form a "V" but be as horizontal to other cable as possible.

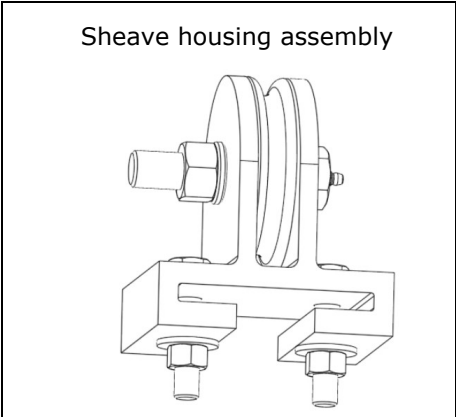

Sheave housing assembly

STEP 2: Cable Routing and Hardware

4K Kits include two 60ft sections of 316 Stainless Steel 7x19 Aircraft Cable with loop and swedge on one end
8K Kits include two 100ft sections of 316 Stainless Steel 7 x 19 Aircraft Cable with loop and swedge on one end

4,000 lb Cable Routing

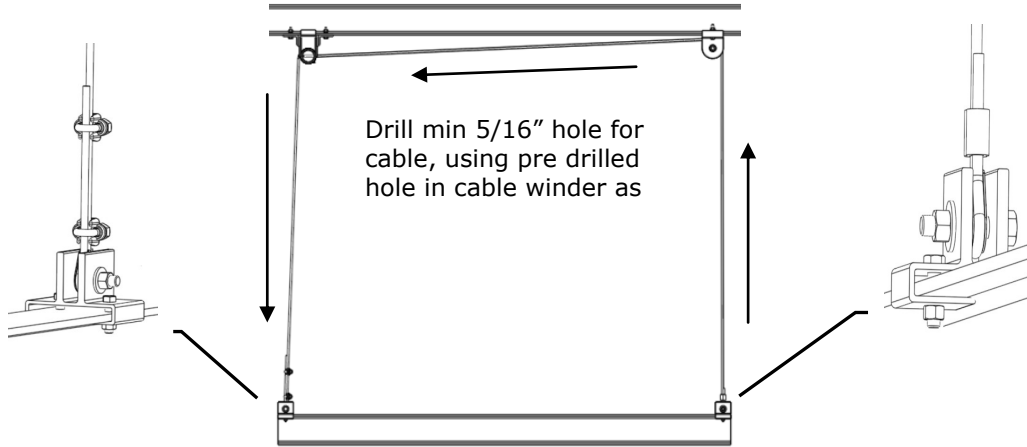

Attach loop end of cable to one side of cradle using 5/8" stainless bolt. Rout cable through sheave, over to pipe, through hole and down to other side of cable. Use stainless steel clamps and thimbles to mount to other side of cradle. You will use the clamp side to adjust cradle to be straight and level. For Sling lifts, use included shackle to attach loop end of cable.

8,000 lb Cable Routing

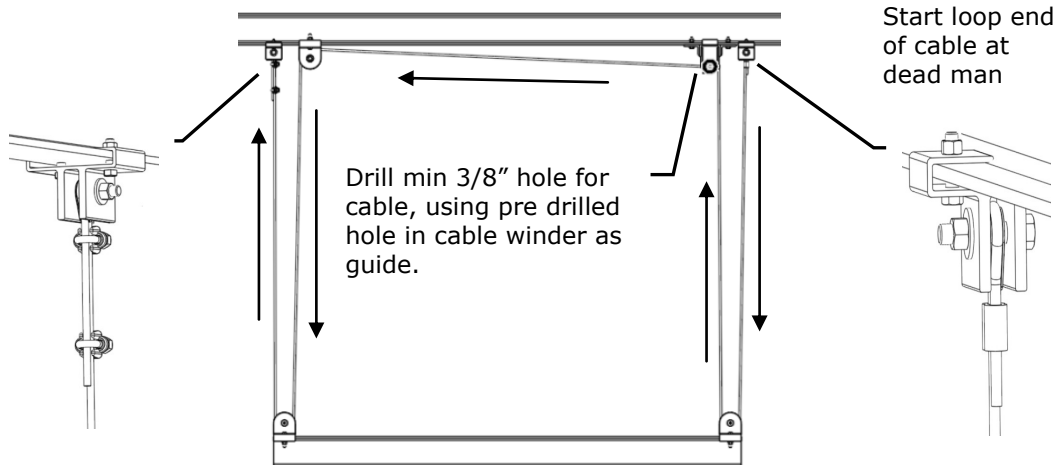

Attach loop end of cable slide on dead man bracket on one side of beam then run cable to sheave on cradle back up to pulley on beam then over and through pipe, back to sheave on cradle then back to dead man

When wrapping cable on cable winder, must insure that one direction of cable spools in opposite direction as other side.

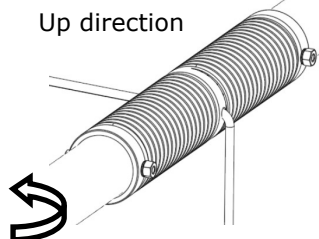

Dead man attach

Use 5/8" Bolts to attach cable to dead man bracket.

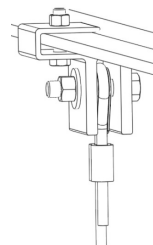

STEP 3: Attaching Gearbox & Motor

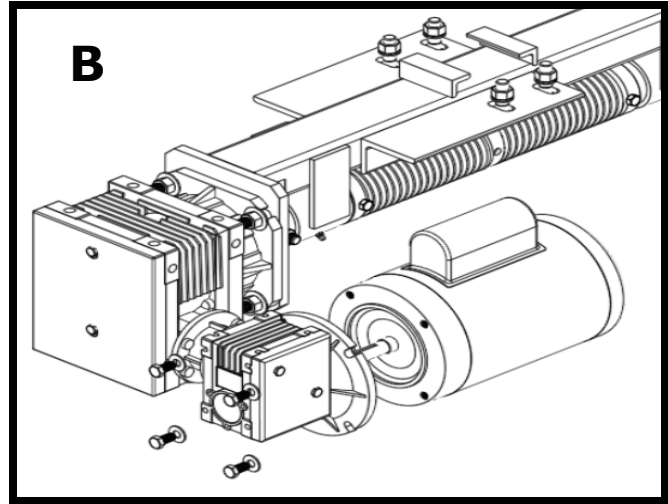
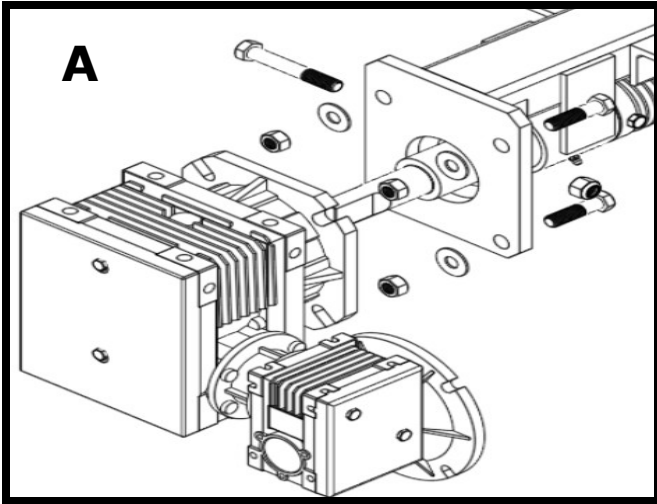

1. Insert drive shaft into pipe and secure with GRADE 5 hardened bolt (included)*
2. Attach Gear Box assembly (no motor) to A-drive hanger. Make sure A drive hanger is secured permanently to beam using the stainless steel hardware included. The Drive shaft inserts into the A-Drive, there is no set screw.
3. Line the motor up with capacitors facing in the up position, never capacitors facing down as they can fill with water. Bolt motor to A-drive with included hardware. **Verify that the drain holes are removed from the bottom of the motor.**

STEP 4: Attaching Bunks or Slings

Attaching V-Hull aluminum bunks to cradle

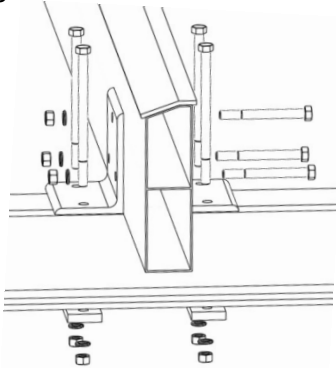

Attaching Pontoon Bunk bracket to cradle

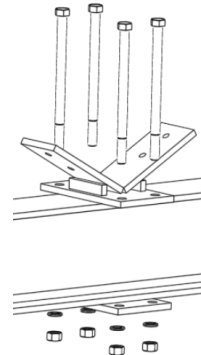

Attaching Weighted Compounding bracket to sling



Attaching sling to cable for 4K lifts

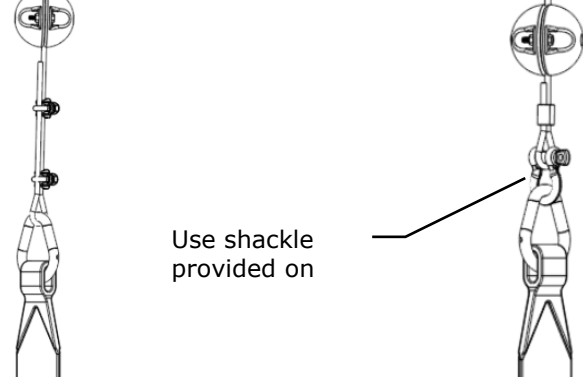

Proper Boat Placement on Cradle

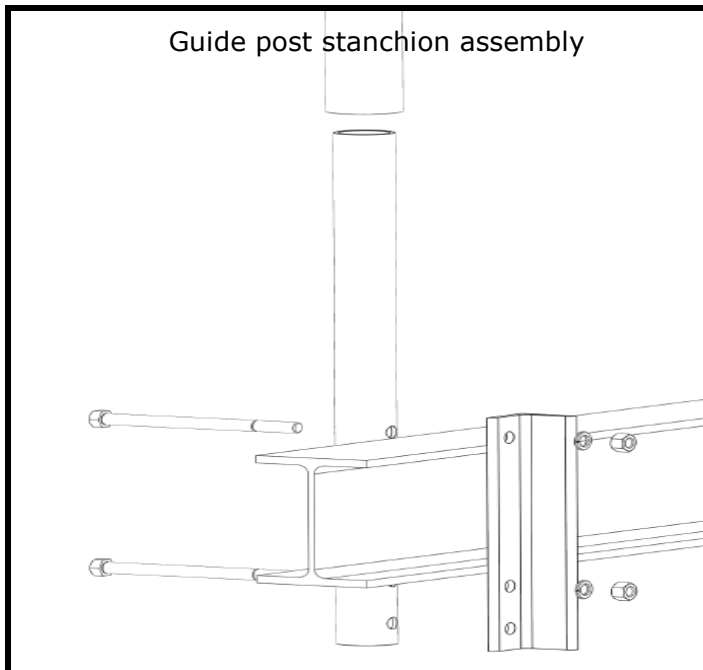
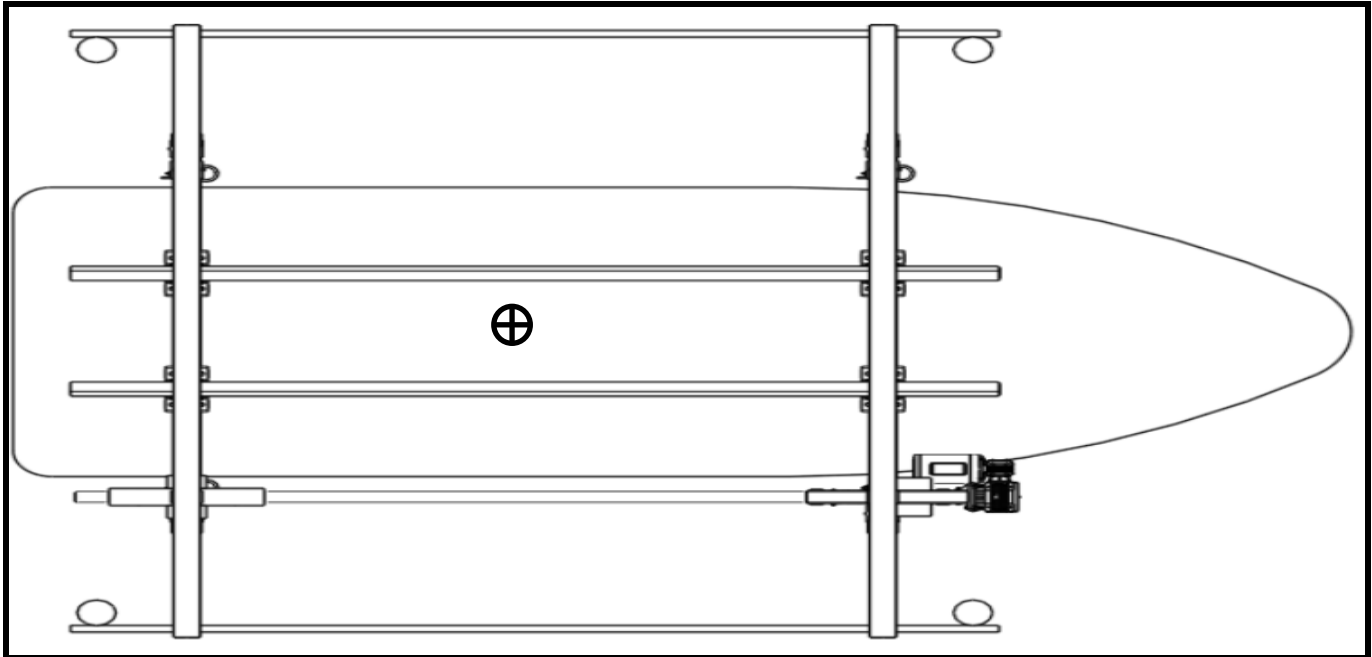

Helpful Hints

1. Mark your guide posts as to when the cradle is low enough to float the boat. This will be a good indicator for tides while you are out enjoying your boat.
2. Get the optional Boat Lift remote control so you can raise your cradle or slings back out of the water to prolong their life.
3. Set your front guide posts in to the curvature of your boat. This will make a good stop when docking.
4. Measure the distance of the inside runners of your boat trailer to get the bunk spread placement needed for your boat

It is the responsibility of the installer and or end user to ensure:

1. The installation is complete and no alterations were made to this lift
2. That all moving pieces have been lubricated
3. Adequate power is supplied to the lift and not using an extension cord or generator
4. GFCI has been tested and is working
5. Cable has been inspected and has no broken strands and shows no signs of distress
6. Cable has been attached properly using proper cable attachment as outlined in this guide
7. Center of gravity of the boat is located by equal deflection of the lift beams or slings.
8. Cable is wrapping on cable winder correctly
9. Switch is permanently mounted and NOT hanging, no electrical cords touching water
10. User understands proper operating and to never be in the boat while on lift or swim around lift.

Boat Lift Electrical Requirements.

Supplying the proper electrical service to you boat lift is required for the lift to operate correctly. Inadequate service will keep the lift from lifting its maximum load and will damage your motor. Your Coastal Series lift has been supplied with a pre-wired and tested Elite Motor.

4000 lb lift 1 hp Elite Stainless motor 120 VOLT 20 AMP circuit
8000 lb lift 1.5 hp Elite Stainless motor 240 VOLT 20 AMP circuit

Each motor comes standard with a lock-on drum switch. The switch has been factory wired and tested. The motor has 16ft 14/5 wire from motor to switch and 5 ft GFCI cord from switch to plug.

For more information about the motors and switches including IP and UL ratings, visit www.bh-usa.com and visit the motors product page.

WIRE SIZE CHART FOR ELECTRIC MOTORS BASED ON DISTANCE FROM SERVICE TO MOTOR													
<small>WIRE REQUIREMENTS THAT ENABLE THE BH-USA HOIST TO OPERATE CORRECTLY WHEN LIFTING STRAIGHT LINE:</small>													
NUMBER OF MOTORS	HP	AMPS TO RUN 115V	AMPS TO RUN 230V	50 FT AT 115V	50 FT AT 230V	100 FT AT 115V	100 FT AT 230V	200 FT AT 115V	200 FT AT 230V	300 FT AT 115V	300 FT AT 230V	400 FT AT 115V	400 FT AT 230V
1	3/4	10.8	5.4	#14	#14	#10	#14	#8	#12	#6	#12	#4	#10
1	1	12.8	6.4	#12	#14	#10	#14	#6	#12	#4	#12	#4	#10
1	1.5	17.0	8.5	#12	#14	#8	#12	#6	#10	#4	#10	#2	#8
2	3/4	21.6	10.8	#10	#12	#8	#12	#4	#10	#2	#8	X	#6
2	1	25.6	12.8	#8	#10	#8	#10	#4	#10	#2	#6	X	#4
2	1.5	34.0	17.0	#8	#10	#6	#10	#2	#8	#0	#4	X	#2

- The electric motor on this lift was wired and tested at BH-USA.
- If your motor starts to lift the boat then stops, check your voltage and confirm your wire to the chart above. This is NOT a motor issue.
- If you un-wire the BH-USA drum switch and re-wire the motor to an existing switch or remote and the motor does not work, check the wiring guides to the manufacture remote or switch you wired too. If in doubt, re-wire the switch you removed the way it was to see if the motor works.
- If your electrician decides to re-wire any of our equipment and feels like our directions are wrong, they assume all liability and warranty (follow our directions please)
- Don't forget to remove the drain plugs on the motor, motors that fill up with water are NOT covered under warranty.
- Using an extension cord or generator will damage the motor and will not be covered under warranty.

SAFETY FIRST!

- A hoist should NEVER be used to lift human beings.
- NEVER use a hoist for any other application, other than the one for which it is designed.
- NEVER put children or adults in a boat while the boat is on a lift.
- NEVER allow children to play in or around a boat while it is on a lift.
- NEVER allow children or adults to swim around or under a boat lift, or near the boat lift when it is submerged.
- NEVER stand on a lift platform if partially submerged, due to the possibility of electric shock.
- NEVER mount or hang a drum switch where it can be reached while in the boat.
- ALWAYS exit the boat and have all passengers exit the boat before lifting the boat.
- NEVER ride the lift while in the boat.
- NEVER leave your boat in the lift with the drain plug open, if the lift drops the boat while you are absent, the boat could fill with water and sink.
- ALWAYS have an operating bilge pump with a functional float switch in any boat on a lift. Rain water can fill the boat adding thousands of pounds that the lift might not be able to handle.

BH-USA supplies a hardened GR5 bolt with all hoists and A-drives, to attach the drive pipe to the hoist. It is the end-users responsibility to ensure that the installer did use the GR5 bolt supplied by BH-USA, using a weaker grade bolt can cause the weaker bolt to fail and drop the boat.

Hoists are not designed, nor intended to lift human beings, or to lift loads over areas where humans might be. Precautions, such as using NEMA and UL components and installing GFCIs on systems and wiring should not be relied upon when the risk of electrocution is possible. Components can fail. For this reason it is NEVER a good idea to swim around a lift. Be vigilant about safety, submerged cables can conduct electricity to the water if your system is not properly grounded, or you have developed a voltage leak.

During the threat of exceptionally bad weather, such as a tropical depression or storm, hurricane or gale force winds, a boat should be removed from the lift and stored on a trailer in a safer place.

Before use, review the BH-USA overhead lift guide and BH-USA equipment guide.